

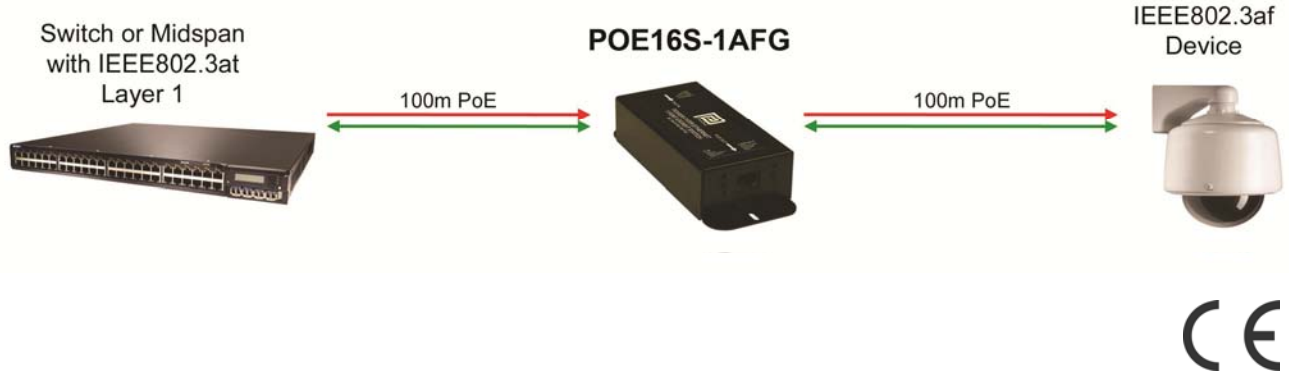

## Single Port PoE Gigabit Switch Powered by IEEE802.3at Extends Ethernet Data and PoE to 200 Meters



### Features

- IEEE802.3af Class 4
- 0-55°C operation
- Gigabit Compatible
- Extends Ethernet to 200meters
- Powered by IEEE802.3at with Layer 1 Classification
- Boost Circuit to Compensate for Wire Drops
- 1 Year Warranty

### Applications

- IP Cameras
- Access Controls
- Wireless Access Points

### Safety Approvals

- CE

### Mechanical Characteristics

- Length: 120mm (4.72in)
- Width: 60mm (2.36in)
- Height: 32mm (1.26in)
- Weight: 0.5Kg (1.1lb)

### Output Specifications

Model	DC Output Voltage	Load		Output Power
		Min.	Max	
POE16S-1AFG	56V	10mA	350mA	19W

PhiHong is not responsible for any error, and reserves the right to make changes without notice. Please visit our website at [www.phihong.com](http://www.phihong.com) for the most up-to-date specifications and contact information.

**INPUT:**

Receives power from Midspan or Switch with IEEE802.3at Layer 1 Classification Class 4 or better

**DC Input Voltage Range**

45 to 57V DC

**DC Input Current**

1.0A at 45VDC and maximum load  
0.8A at 57VDC and maximum load

**Output**

19W

**Ripple & Noise (Vp-p)**

100mV max

**PoE Standard Compliance**

**Input**

25K Internal Signature Resistance

**Output**

Detects a 25K Signature Resistance

**ENVIRONMENTAL:**

**Temperature**

Operation 0 to +55°C  
Non-operation -20 to +71°C

**Humidity**

Operation 5 to 90%

**Input and Output Data Connector**

RJ45

**Immunity**

ESD: EN61000-4-2. Level 3  
RS: EN61000-4-3. Level 3  
EFT/Burst: EN61000-4-4. Level 2  
Surge: EN61000-4-5. Level 2  
Note: RS tested with POE36U-1AT

**EMC**

EN55022 Class A  
FCC part 15 Class A

**Isolation Test**

Input to F.G.: 2121VDC for 1 min, 10mA  
Output to F.G.: 2121VDC for 1 min, 10mA

**Insulation Resistance**

Input to F.G.: >10M OHM 500VDC  
Input to F.G.: >10M OHM 500VDC

**Indicators**

Ethernet -In (1 blinking as indicator)	Green LED 1 – 10Mb activity Green LED 2 – 100Mb activity Green LED 3 – 1000Mb activity
Ethernet – Out (1 blinking as indicator)	Green LED 1 – 10Mb activity Green LED 2 – 100Mb activity Green LED 3 – 1000Mb activity
POE	Green LED 1: Input power “ON” Red LED: Fault detected Green LED 2: Valid IEEE802.3af load detected and connected

**Dimension Diagram Unit: mm**

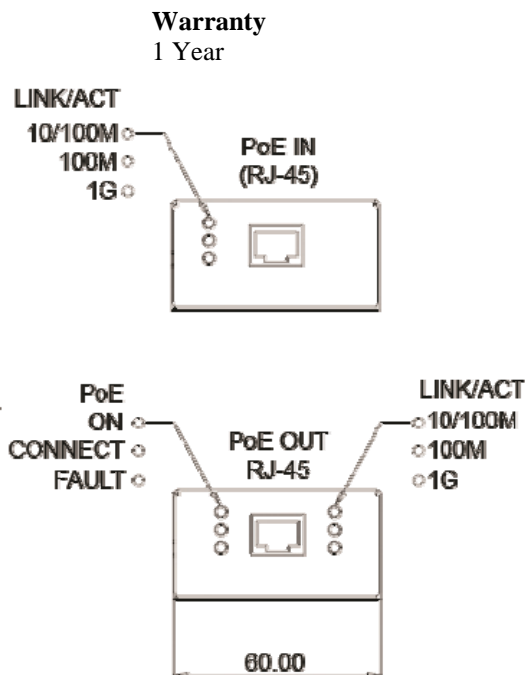
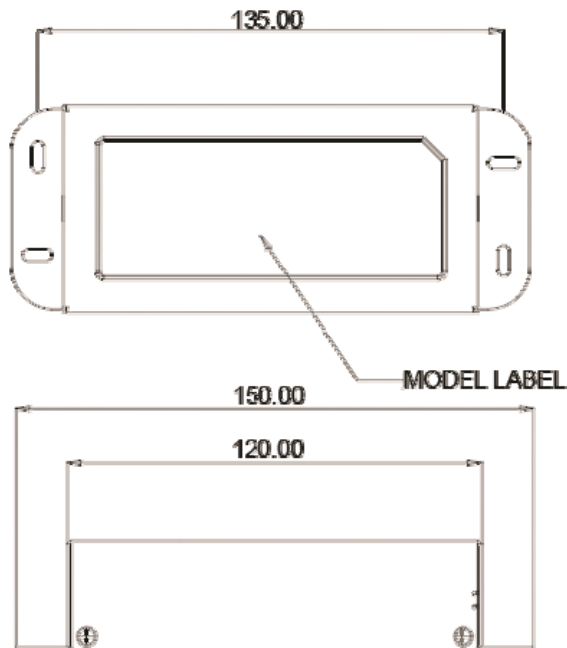

**Cable**

Designed to operate up to 100 meters per IEEE802.3, CAT 5e or CAT 6

**Warranty**

1 Year



## Description of LED Functions for Gigabit Power Extender

### Power-up Sequence:

Upon power-up, all 3 LEDs will light for 2 seconds, as part of the self-test for the internal microprocessor software. After the 2 seconds, the "ON" LED will illuminate green. The DC output voltage is now available for powering a compliant load (to the 802.3af PoE standards).

### Detection Sequence:

Once a compliant load is attached to the output RJ45 connector, the green "CONNECT" LED will illuminate.

Should the load be non-compliant then the LEDs will blink a code signifying the cause for non-detection.

Detection Failure Codes:

1. Incorrect resistive signature – The green "CONNECT" and red "FAULT" LEDs will blink 3 times.
2. Incorrect capacitive signature – The green "ON" LED will blink 3 times.
3. Incorrect Voffset – The green "CONNECT" and green "ON" LEDs will blink 3 times.
4. Unstable current measurement – The green "ON" LED will blink 3 times
5. Low voltage sensed during detection (overload) – The red "FAULT" LED will blink 3 times

After the LEDs blink 3 times the Power Injector will continue to try to detect a valid load. Until the correct load is applied, the LEDs will continue to blink. If there is an open circuit connected to the output RJ45 then the LEDs will not blink but the Power Injector will continue to try to detect a valid load.

### Fault Sequence:

Should a fault occur such as an overload or short circuit then the red "FAULT" LED will illuminate. The red "FAULT" LED will illuminate for 2 seconds and then go off as the power supply tries to re-detect a valid load. If there is a problem detecting the load, the LED will indicate the possible fault as per the codes in the section above.